

Elon® 100 Commissioning Checklist for Installers

V1.01



NOTE: This Commissioning Checklist is intended for installers and not general users. Users should please refer to the User Manual, which can be found at www.poweroptimal.com/manuals. This is NOT a replacement for the Installation Manual. Installers must follow the installation instructions in the Installation Manual, which can be found at the above link. **All Elon installations must be signed off by a registered electrician, who must issue a supplementary CoC.**

Customer name		Date		Elon® serial no.	
Installation address					
Installer name		Installer signature			

Commissioning Steps / Tests

1. Once installation is complete, do the following:
 - a. Turn the control dial to "SOLAR ONLY".
 - b. Switch on the AC & DC circuit breakers or isolators.
 - c. Remove the covering from the solar modules.
 - d. Switch on the geyser circuit breaker at the main DB.

No.	Action	Result	Units
2	Confirm correct wiring and confirm DC polarity to Elon® as per basic wiring diagram on next page. Also confirm test meter wires are connected correctly, black to common!	<input type="checkbox"/>	
3	Confirm correct voltages and currents of all connections through the following steps:		
3a	Confirm open / closed thermostat voltages (11 – 14 V DC open, 0 V DC closed). Leave thermostat in closed position for rest of testing. If water is already at setpoint (e.g. 55 or 60 °C), indicated by a solid green light on the controller, increase thermostat temperature setting or open a hot water tap in the house to drain some hot water.		V DC (open)
			V DC (closed)
3b	Confirm controller wire is connected properly. The connections should “click” into place and appropriate LEDs should indicate (be active).	<input type="checkbox"/>	
3c	With dial on “SOLAR ONLY” and solar power flowing to element (green LED flashing), confirm same DC voltage to element as measured at solar terminals.		V DC solar
			V DC element
3d	With DC clamp meter confirm that there is an active current through element by measuring the current of one of the wires going from Elon® to element.		A DC
3e	Turn dial to “MAINS ONLY”. Note that the Elon® will only switch to mains 5 min after mains power switch-on or reconnection. With mains power flowing to element (red LED flashing), confirm same AC voltage to element as measured at mains terminals (should be approx. 230V AC).		V AC mains
			V AC element
3f	With AC clamp meter confirm active current through element of between 9 and 18 Amps depending on element rating.		A AC
4	If you used a test controller for commissioning, remember to plug the wire from the installed controller back into the Elon® and check functioning.	<input type="checkbox"/>	
5	Set thermostat back to original setting.	<input type="checkbox"/>	
6	Set control dial to setting “2” (the 6 o’clock position).	<input type="checkbox"/>	

Elon® 100 Commissioning Checklist for Installers

V1.01



Basic wiring diagram for Elon® 100

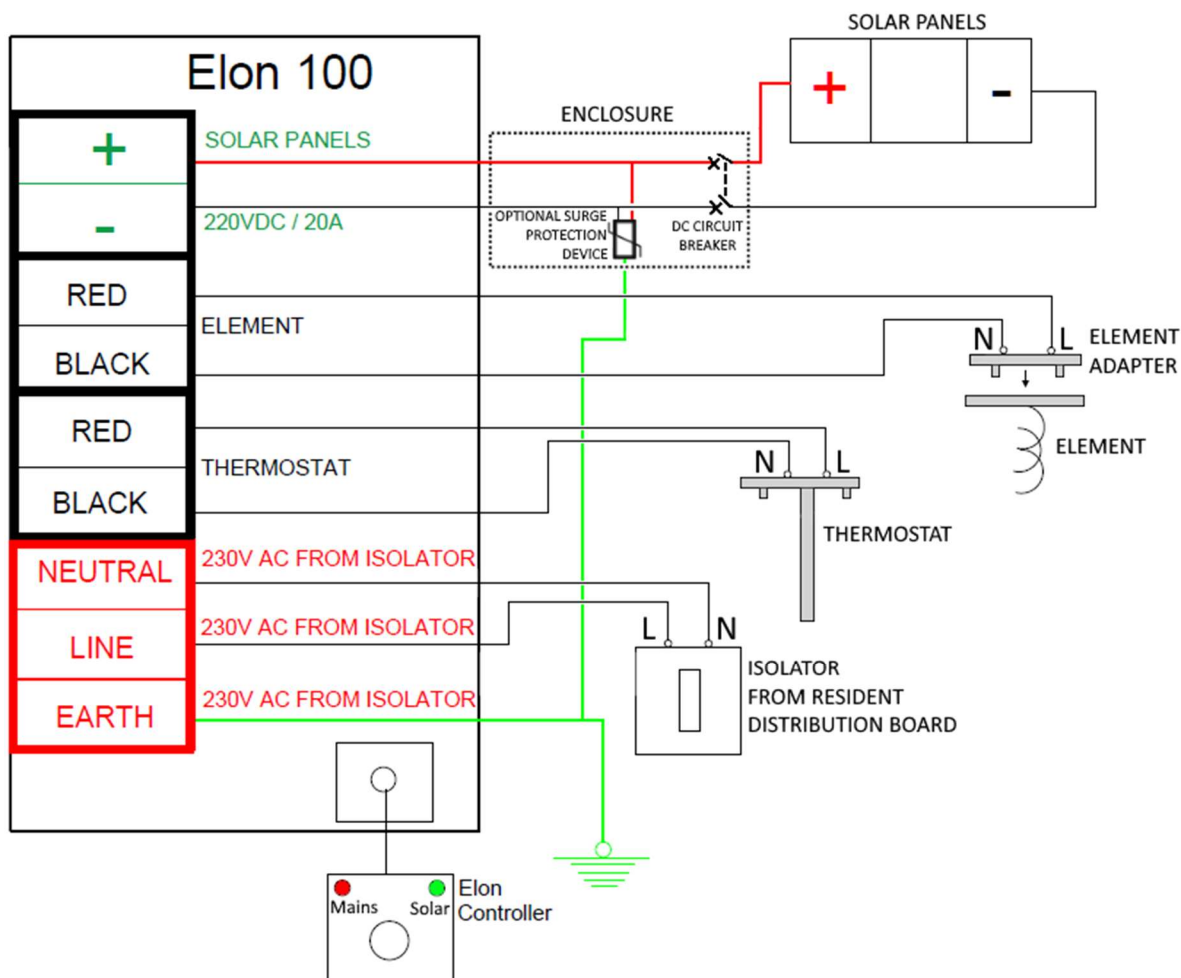

Things to Remember

- The **red mains LED** will only start functioning once stable mains voltage between 190 and 260 V AC is present for more than **5 minutes**. (In other words, the Elon® will only allow mains power to the element 5 minutes after mains connection or switch-on.)
- **Solar power** is only recognised **40 seconds** after active solar panels are connected to Elon®.
- An **open thermostat** (water at correct temperature) measures between **11 and 14 V DC** across the “thermostat” terminals on the Elon®. Polarity across these terminals is not important.
- A **closed thermostat** (cold water) **measures 0 V** across the “thermostat” terminals on the Elon®.
- **How to switch on solar power to element:** With enough solar energy (check at solar terminals), solar power will be routed to the element within 15 seconds after the thermostat closes and the controller dial is set to “**SOLAR ONLY**”. A green flashing LED indicates this condition.
- **How to switch on mains power to element:** Turn control dial to “**MAINS ONLY**” and, if the thermostat is closed, mains power will be directed to the element indicated by a red flashing LED.
- **Note:** Once the dial has been turned to “**MAINS ONLY**”, it will complete a full mains heating cycle (until the thermostat opens). Turning the control back to “**SOLAR ONLY**” at this point **will NOT immediately switch the unit back to solar power**. It will only switch back again after the mains heating cycle is completed (i.e. the thermostat opens) and the thermostat then closes again. You can finish the mains heating cycle faster by reducing the thermostat temperature setting until the thermostat opens. **Test solar power first.**