

Elon® 100 Troubleshooting Basics for Technicians V2.3



NOTE: This Troubleshooting Guide is intended for technicians and not general users. Users should please refer to the User Manual, which can be found at www.poweroptimal.com/manuals. Please see page 7 for a summary of the Elon®'s controller and LED lights. **You will need an AC & DC Multimeter with clamp adapter. Always check the PowerOptimal website for the latest version of this guide.**

Information about the Site

Unit no.		Development name		Elon® serial no.	
Date		Name: 1 st level support person			
Unit construction status (Works OR Final Completion)		Resident name			
Reported issue (customer)				Reported issue (Level 1 Support)	

A Few Notes Before You Start

- If you have a test / extra remote control (little black box with the control dial & lights), plug it into the Elon® unit.
- If you identify the problem at a specific step, you can stop there and write your conclusion.
- If you replace an Elon®, thermostat, element or wiring, you should commission the system again as per the Installation Manual.

On Arrival at Site – Preparation Checks

No.	Action	Notes	Result / Comments
1	Talk to Client / Manager to find out what the issue is.	Was it a new install or a retrofit? Was the issue present from the start, or did the issue start some time after installation?	<input type="checkbox"/>
2	Is geyser AC on at house DB?	Check that the geyser is switched on at the main house DB. Is there power in the house (i.e. it's not loadshedding or no prepaid credits)?	<input type="checkbox"/>

Elon® 100 Troubleshooting Basics for Technicians V2.3

No.	Action	Notes	Result / Comments
3	Is there a geyser timer installed?	Check if there is a separate geyser timer installed at the house DB or elsewhere on the AC wiring to the geyser. A separate timer is NOT recommended, as it will work at cross-purposes with the Elon and you will reduce performance and hot water availability. Uninstall or bypass the geyser timer.	<input type="checkbox"/>

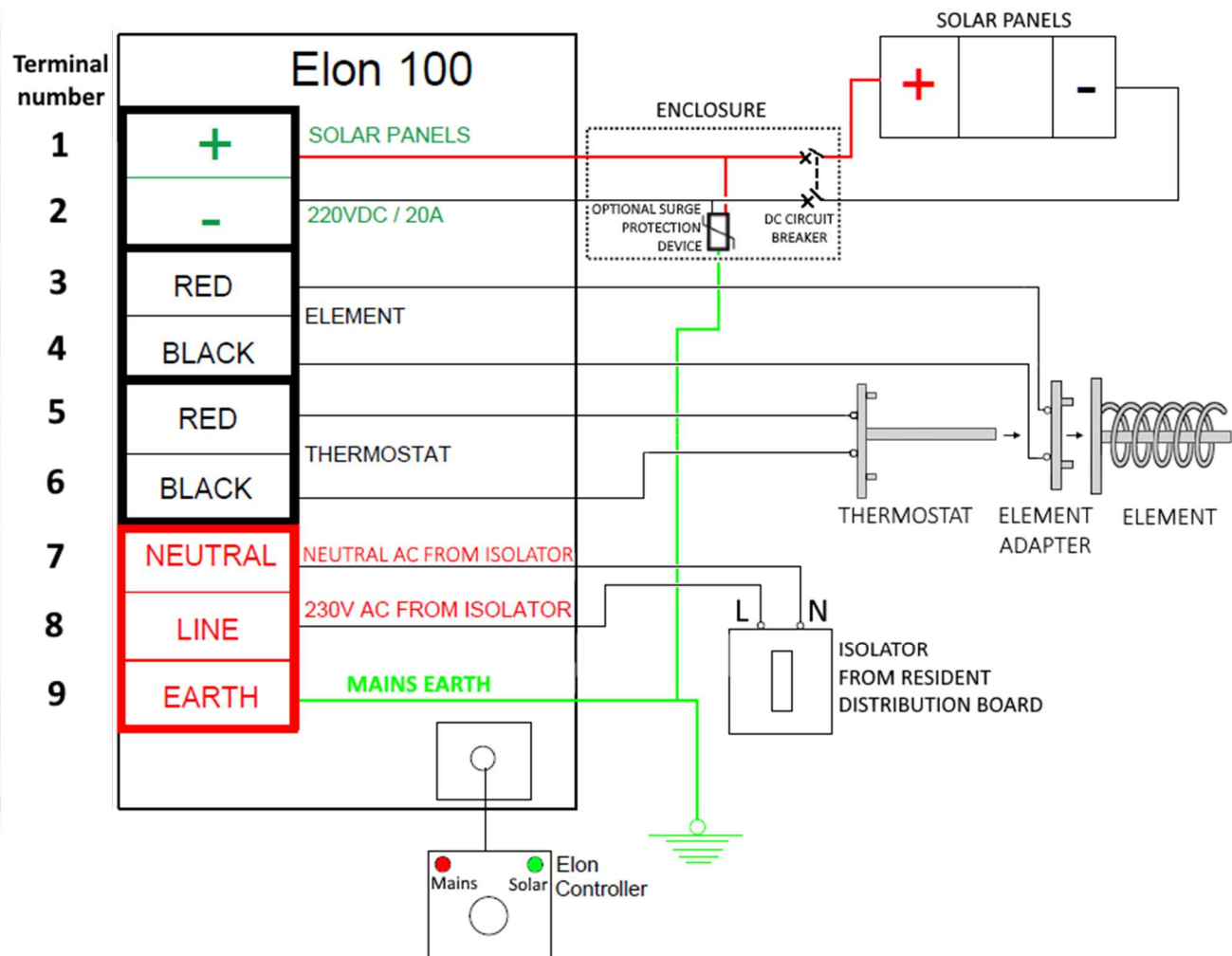
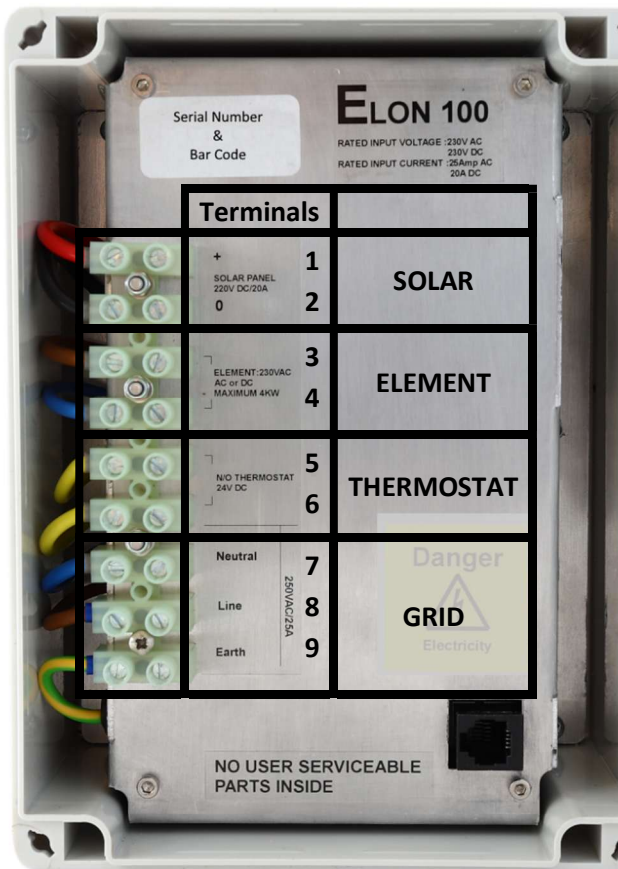

Elon® 100 Troubleshooting Basics for Technicians V2.3



When You are at the Geyser & Elon unit

No.	Action	Notes	Result / Comments
1	Is geyser AC isolator on?	Check that the AC isolator is switched on. The isolator will be within 2m of the geyser.	<input type="checkbox"/>
2	Check that all the wiring to the Elon unit is correct	<p>Take off (unscrew) the lid of the Elon 100 unit.</p> <p>See the wiring diagram on the previous page for reference. Confirm that:</p> <ol style="list-style-type: none"> Solar panels are connected to Elon terminals 1 & 2 (marked "SOLAR PANEL") Terminals marked "ELEMENT" on green element adapter (plugged into geyser element) are connected to Elon terminals 3 & 4 (marked "ELEMENT") Thermostat is connected to Elon terminals 5 & 6 (marked "THERMOSTAT") Grid power (neutral, line, earth) is connected to Elon terminals 7, 8 and 9 (marked "NEUTRAL", "LINE" and "EARTH") 	<input type="checkbox"/>
3	Set thermostat to 10 °C and turn Elon remote control dial to "SOLAR ONLY"		<input type="checkbox"/>
4	Confirm correct polarity and check voltage of solar power (DC) input	Use your multimeter to check polarity at terminals 1 & 2. (Set multimeter to DC voltage measurement. You should measure a positive voltage with the red probe touching terminal 1.) Check the DC voltage – it should be between 70 and 240V DC in good sunlight, depending on the number of solar panels.	<input type="checkbox"/> _____ V DC
5	Check voltage of grid power (AC) input	Set multimeter to AC voltage measurement. Check the AC voltage on terminals 7 & 8 – it should be between 200 and 250V AC.	_____ V AC

Elon® 100 Troubleshooting

Basics for Technicians V2.3



No.	Action	Notes	Result / Comments
6	Confirm that thermostat is open	Set multimeter to DC voltage. Check DC voltage on terminals 5 & 6 – it should be between 11.5 and 13.5V DC . Polarity is not important.	_____ V DC
7	Confirm no power output to geyser	Confirm 0V DC and 0V AC on terminals 3 & 4 using your multimeter.	<input type="checkbox"/>
8	Confirm steady red & green lights on remote control	Both the red and green lights should be on. (Note that it will take 5 min from switching on AC power to the Elon before the red light will come on.) If both lights on the remote control are off, follow the steps in item no. 3 in the “Things to remember” section on page 6.	<input type="checkbox"/>
9	Set thermostat to 70 °C	The green LED should now switch off (indicating water temperature below thermostat set point temperature)	<input type="checkbox"/>
10	Check that thermostat is closed	Set multimeter to DC voltage. Check DC voltage on terminals 5 & 6 – it should be 0V (zero V). Polarity is not important. If not 0V now, thermostat might be faulty OR thermal fuse on element adapter might have blown – check if there is continuity on the element adapter thermostat female terminals. If there is no continuity, the thermal fuse has blown & you need to replace the element adapter.	<input type="checkbox"/>
11	Check that solar power is feeding to geyser	Green light on remote control should be flashing. Confirm presence of DC voltage on terminals 3 & 4 . It should be the same DC voltage as on terminals 1 & 2.	<input type="checkbox"/>
12	Check that DC circuit breaker / isolator is not faulty	Measure voltage across DC circuit breaker whilst the element is drawing DC power. The voltage should be very close to zero. If there is a significant voltage across the DC circuit breaker, it is faulty and should be replaced. Also check any DC fuses if installed.	<input type="checkbox"/>
13	Turn Elon remote control dial to “AC only”		<input type="checkbox"/>

Elon® 100 Troubleshooting

Basics for Technicians V2.3



No.	Action	Notes	Result / Comments
14	Check that grid power is feeding to geyser	Red light on remote control should be flashing & green light should be off. Confirm presence of AC voltage on terminals 3 & 4 . It should be the same AC voltage as on terminals 7 & 8.	<input type="checkbox"/>
15	Set Elon remote control dial back to original setting (setting "3" or "SOLAR ONLY")		
16	Set the thermostat to 10 °C for about 10 seconds and then set it to original set point (e.g. 55 °C or 60 °C)	Check that unit switches back to solar mode in daytime. If customer needs hot water immediately, you can request one cycle of grid heating by turning the remote control dial to "MAINS ONLY" for a few seconds (until the red light starts flashing) and then turning it back to original set point.	

What was the issue?	
What did you do to fix it?	

For assistance call Johan Theron @ 083 600 1827

Things to Remember

1. **Note:** Once the dial has been turned to “**MAINS ONLY**”, it will complete a full mains heating cycle (until the thermostat opens). Turning the control back to “**SOLAR ONLY**” at this point will not immediately switch the unit back to solar power. It will only switch back again after the mains heating cycle is completed (i.e. the thermostat opens) and the thermostat then closes again. You can finish the mains heating cycle faster by reducing the thermostat temperature setting until the thermostat opens. **Test solar power first.**
2. **Fast flashing red / green LEDs** indicate either:
 - a. a short between a PV (photovoltaic) lead and earth – this condition prevents solar power to the element;
 - b. a partial short of the element to earth, e.g., a puncture exposing element to water. This condition can be ruled out by disconnecting both wires to the element. If the LEDs stop flashing after about 20 seconds, the element is faulty. If the LEDs continue flashing, then the cause is likely as per item a. above.
 - c. **Please note:** wait at least 20 seconds after any disconnection or other correction step for the LEDs to stop flashing.
3. If **no lights on remote control**, then follow these steps:
 - a. Check that the remote control cable is properly (fully) inserted at both ends (both at the Elon and the remote control).
 - b. Change out the remote control. If lights now come on, the remote control is faulty. You can service the remote control by opening it up, spraying the inside with contact cleaner, turning the dial a few times and retesting. If this doesn't work, install the new remote control.

Elon® 100 Troubleshooting







Basics for Technicians V2.3

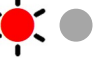

- c. If lights still don't come on, plug a new cable and the old remote control into the Elon. If the lights now come on, the remote control cable is faulty. Install the new cable.
- d. If the lights still don't come on, either all power to the Elon is off, or the Elon is faulty.

Elon® 100 Troubleshooting Basics for Technicians V2.3

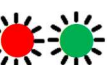
The Mains & Solar indicator lights (LEDs) indicate the following conditions:

Lights (LEDs)	Meaning
	Green light ON Geyser on temperature
	Green light flashing Heating with solar
	Red light ON Mains power available (power to Elon® unit on)
	Red light flashing Heating with mains
	Both lights ON Geyser is on temperature. Mains power available (mains power to Elon® unit on)
	Red light ON & Green light flashing Heating with solar. Mains power available (mains power to Elon® unit on)
	Red & Green light flashing fast Isolation fault (contact electrician)
	Both lights OFF No power to unit (e.g. no sun + power failure, or no sun + geyser breaker at DB board is switched off) OR supply voltage outside specifications

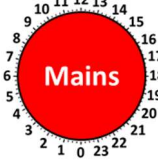
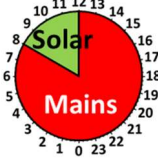
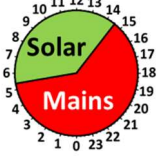
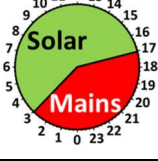
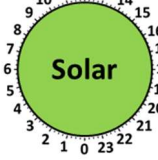

The control dial sets the mains & solar times as follows:

Dial Setting	Time on Mains*	Time on Solar*	24-Hour Clock
MAINS ONLY	24 hr	Never	
1	12:00 to 08:00	08:00 to 12:00	
2	14:30 to 05:30	05:30 to 14:30	
3	17:00 to 03:00	03:00 to 17:00	
SOLAR ONLY	Never	24 hr	

* Times are approximate – will vary slightly with season and location

Elon® 100 Troubleshooting Basics for Technicians V2.3

Pictures of main items



Elon 100 main unit with lid on



Elon 100 remote control



Element adapter



Elon 100 main unit with lid off



Example AC/DC multimeter

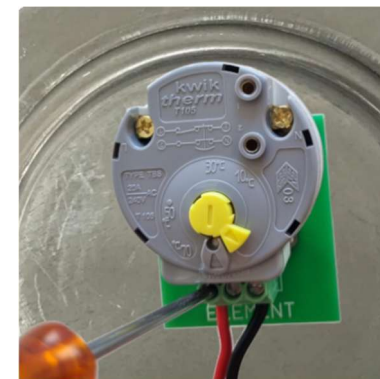

Element adapter plugged into geyser element, with thermostat plugged into element adapter